

INSIDE THIS ISSUE

PG. 2

WEEK SYNOPSES

SPONSOR SPOTLIGHT

PG. 3

2024 GAME: CRESCENDO

PG. 4

DEPARTMENTS UPDATED

PG. 5

CAD DESIGNS

PG. 6

TEAM SPOTLIGHTS

MENTOR SPOTLIGHTS



TEAM 223 XTREME HEAT

GRACIOUS PROFESSIONALISM:

THE *FIRST* ETHOS OF *GRACIOUS PROFESSIONALISM* ENCOURAGES HIGH-QUALITY WORK, EMPHASIZES THE VALUE OF OTHERS, AND RESPECTS INDIVIDUALS AND THE COMMUNITY IN PURSUIT OF A MEANINGFUL LIFE.

“THINK OF *FIRST* AS A CATALYST IN A CHAIN REACTION. EACH COLLISION RELEASES HUMAN POTENTIAL WHICH FEEDS AN EXPONENTIAL EXPANSION OF ADDITIONAL HUMAN POTENTIAL. *FIRST* STUDENTS SEIZE THIS OPPORTUNITY BY BEING INFORMED, BEING CREATIVE, AND THINKING HARD – ALL THREE, ALL THE TIME.

– DR. WOODIE FLOWERS



SPONSOR SPOTLIGHT: A HUGE THANK YOU TO JOHNSON AND JOHNSON FOR THEIR CONTINUED SUPPORT FOR RUNNING OUR ANNUAL GOLF OUTING!

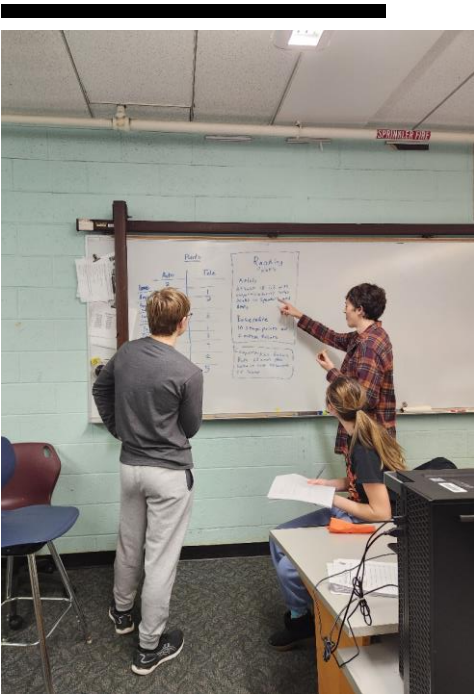

WEEK SYNOPSSES

WEEK 1

STARTING WITH THE KICK OFF, EVERYONE READ THE GAME MANUAL AND COMBINED FORCES TO THINK OF STRATEGIES AND SOLUTIONS FOR OUR NEW GAME, CRESCENDO. GOING INTO WEEK 1, THE IDEAS THAT HAD BEEN FORMED DURING THE KICK OFF WERE USED TO CONSIDER STRATEGY, DESIGN ELEMENTS, AND TO LOOK FOR INSPIRATION FROM OTHER RESOURCES. OUR BUSINESS TEAM ALSO WAS HARD AT WORK TO COLLECT PHOTOS AND VIDEOS, AS WELL AS WORKING ON OUR SUBMISSION FOR THE WOODIE FLOWERS AWARD.

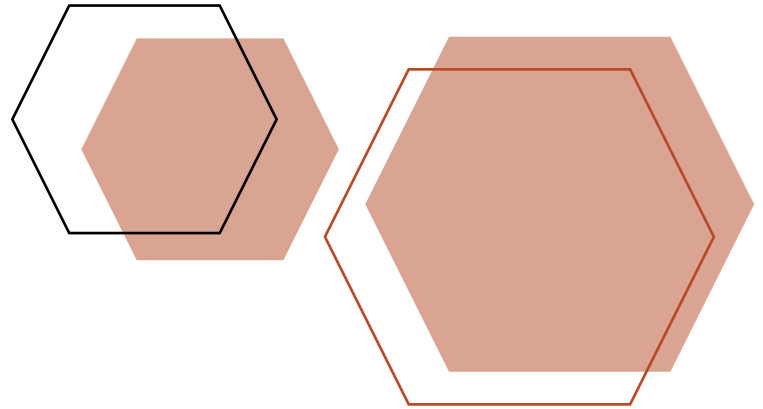

WEEK 2

DURING WEEK 2, EVERYONE HAS BEEN HARD AT WORK. THE BUSINESS DEPARTMENT HAS BEEN COMING UP WITH T-SHIRT CONCEPTS, CONTINUING TO WORK ON THE WOODIE FLOWERS AWARD SUBMISSION, AND CREATING THIS NEWSLETTER. THE DESIGN AND BUILDING DEPARTMENT HAS BEEN WORKING TO CREATE AN INTAKE, ALONG WITH AN ELEVATOR AND A-FRAME. THEY HAVE ALSO BEEN WORKING ON A PROTOTYPE FOR OUR SHOOTER, AND BUILDING A KITBOT. THE PROGRAMMING DEPARTMENT HAS BEEN WORKING ON TEACHING OUR ROOKIES THE BASICS OF CODING.

CRESCENDOSM

PRESENTED BY 
Gene Mann Foundation

2024 SEASON *FIRST* ROBOTICS CHALLENGE

CRESCENDO

FIRST ANNUALLY CREATES AND ENGINEERING GAME TO CHALLENGE HIGH SCHOOL STUDENTS. THEY PROMOTE SKILLS THAT CAN BE USEFUL THROUGHOUT THEIR LIVES. SOME SKILLS THEY DEVELOP ARE STRATEGY SKILLS, ELEMENTS OF TEAMWORK, LEADERSHIP SKILLS AND MOST IMPORTANTLY, THE IDEA OF GRACIOUS PROFESSIONALISM. *FIRST* RELEASES A GAME REVEAL VIDEO ALONG WITH OTHER HELPFUL TOOLS ON A SPECIFIED DATE EACH YEAR WHICH THEN BEGINS THE 6 WEEK BUILD SEASON.

THIS YEAR'S GAME, *CHARGED UP* WAS RELEASED ON SATURDAY, JANUARY 6TH. THE STUDENTS ON EXTREME HEAT 223 GATHERED AROUND THE SCREEN PROJECTION TO SEE THIS SEASON'S CHALLENGE. AFTER THE REVEAL THEY ALL READ THE GAME MANUAL IN ORDER TO UNDERSTAND THE FINE DETAILS. THEY CONSIDERED RULES, PENALTIES, OBJECTIVES, SCORING METHODS, AND POSSIBLE OUTCOMES OR COMPONENTS THEY WANTED IN THEIR ROBOT.



DEPARTMENTS UPDATED

DESIGN & BUILDING

- DISCUSS GEOMETRY OF POSSIBLE ROBOTS
- LOOK FOR INSPIRATION IN OTHER RESOURCES
- STARTED DESIGNING PROTOTYPE
- BUILT A SHOOTER
- BUILDING A KITBOT

STRATEGY

- BRAINSTORM POSSIBILITIES OF TASKS OUR ROBOT WILL COMPLETE

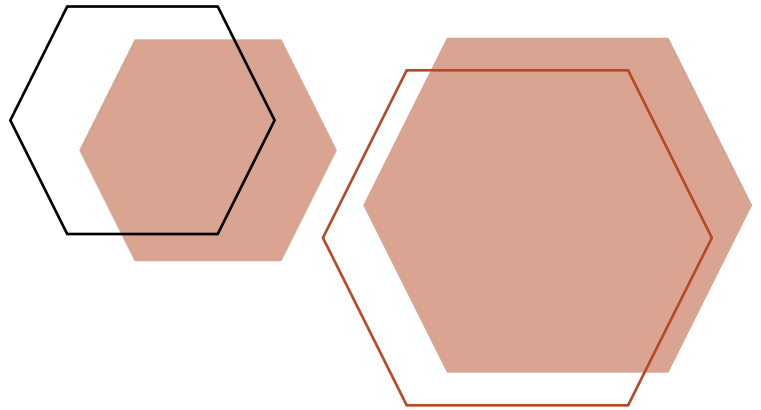

BUSINESS

- WOODIE FLOWERS AWARD ESSAY
- WEBSITE DESIGN
- NEWSLETTER COMPOSITION

PROGRAMMING

- UPDATED ALL LIBRARIES
- REFACTORED CODE
- TAUGHT ROOKIES BASICS

CAD DESIGNS

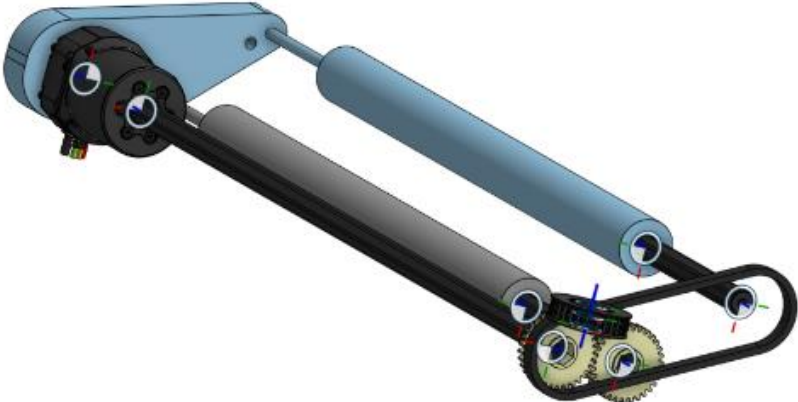
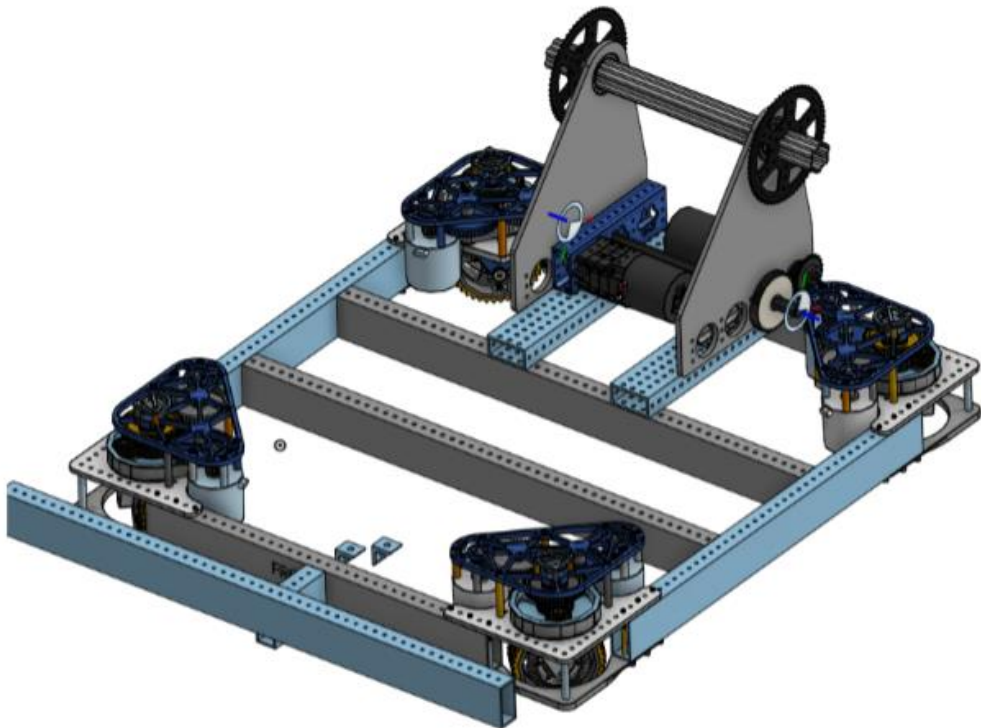



MENTOR SPOTLIGHT

TYLER GUAHAROU

MY NAME IS TYLER. I AM A MENTOR FOR THE TEAM AND I DISCOVERED THE TEAM AT THE CLUB FAIR MY FRESHMAN YEAR. I JOINED BECAUSE I HAVE ALWAYS HAD A PASSION FOR ENGINEERING AND ROBOTICS. WHEN I WAS YOUNG I HAD A LEGO ROBOTICS KIT THAT I USED TO MAKE ALL KINDS OF MECHANISMS FOR MY HOUSE. AT ONE POINT I HAD MADE A ROOMBA OUT OF LEGOS. JOINING TEAM 223 WAS MY NEXT EVOLUTION. I HELP THE TEAM IN ANY WAY I CAN. THIS USUALLY COMES FROM HELPING STUDENTS DESIGN AND BUILD THE ROBOT. I DO THIS BY HELPING THEM WITH ISSUES THEY ARE HAVING OR SHOWING THEM HOW TO ACCOMPLISH A TASK BUT TRULY UNDERSTAND WHY WE MADE THE DECISION WE DID FOR THAT TASK. A FUN FACT ABOUT ME IS THAT I DESIGN HOME THEATERS FOR PEOPLE AND ALSO HAVE ONE OF MY OWN.

STUDENT SPOTLIGHT

LEXI C

MY NAME IS LEXI, I AM A SENIOR AND I AM TEAM 223'S DESIGN AND TEAM CAPTAIN. I HAVE BEEN ON THE TEAM FOR 4 YEARS. IN 8TH GRADE, I WENT TO LAKELAND'S OPEN HOUSE AND THE TEAM WAS PRESENTING. I IMMEDIATELY WANTED TO JOIN, IT TURNED OUT MR. COREN WAS MY TEACHER SO HE INTRODUCED ME TO THE TEAM. SO FAR I HAVE LEARNED HOW TO DESIGN AND BUILD A ROBOT, IMPROVED MY PUBLIC SPEAKING SKILLS, AND I HAVE BEEN ABLE TO TALK TO PEOPLE MORE CONFIDENTLY. MY FAVORITE MEMORY HAS BEEN BEING A FINALIST AT WARREN HILLS LAST YEAR. WE ALMOST GOT A BLUE BANNER! ONE THING I HAVE DONE SO FAR THIS SEASON IS CAD OUR A-FRAME AND BUILD OUR SHOOTER PROTOTYPE. A GOAL I HAVE THIS YEAR IS TO BUILD A GREAT ROBOT AND BECOME A FINALIST IN ALL OF OUR COMPETITIONS. I WOULD ALSO LOVE TO GO TO HOUSTON FOR THE WORLD CHAMPIONSHIPS!

STUDENT SPOTLIGHT

JANET H

MY NAME IS JANET, I AM A SENIOR AND I AM TEAM 223'S BUSINESS CAPTAIN. I HAVE BEEN ON THE TEAM SINCE I MOVED TO NEW JERSEY MY SOPHOMORE YEAR. I JOINED THE TEAM WHEN ONE OF MY FRIENDS INVITED ME TO A MEETING AND I FELL IN LOVE WITH THE ENERGY OF THE TEAM. I STARTED AS PART OF THE BUILD TEAM AND STILL ENJOY OCCASIONALLY JUMPING IN TO HELP WHEN I AM NEEDED. SOME OF THE THINGS I HAVE LEARNED ON THE TEAM ARE HOW TO USE OUR CNC ROUTER MACHINE, HOW TO CREATE CONTENT ON SOCIAL MEDIA, AND HOW TO WRITE PROFESSIONAL EMAILS. SOME THINGS I'VE DONE THIS SEASON ARE COMMUNICATE WITH SPONSORS, UPDATING SOCIAL MEDIA, CREATE NEWSLETTERS, AND START THE PROCESS TO DESIGN A T-SHIRT. THIS SEASON I WOULD LIKE TO BE ABLE TO SUCCESSFULLY PREPARE THOSE IN THE BUSINESS DEPARTMENT, FOR MY DEPARTURE AT THE END OF THE YEAR. THIS INCLUDES TEACHING THEM HOW TO COMPLETE THE TASKS THAT ARE MY RESPONSIBILITIES SO THAT I FEEL CONFIDENT LEAVING THIS TEAM IN GREAT HANDS. MY FAVORITE MEMORY IS ALWAYS THE FUN TIMES WE HAVE DURING OUR LATE NIGHTS ON THURSDAYS.

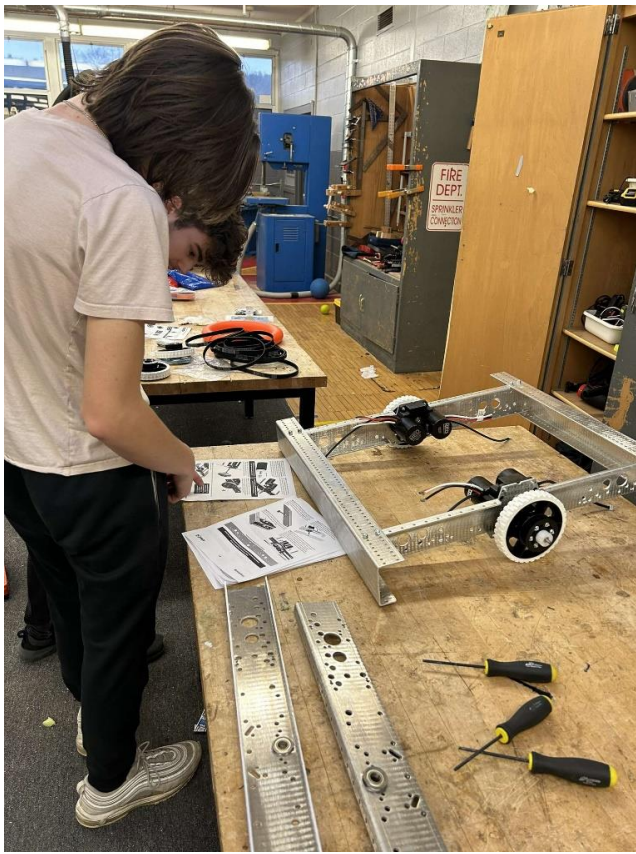

THANK YOU FOR SUPPORTING OUR TEAM!

CONTACT US

FRC TEAM 223 XTREME HEAT

CONTACT PERSON: RANDY COREN

205 CONKLINTOWN ROAD, WANAQUE, NJ, 07465

973-835-1900 EXT. 798

TEAM223@LAKELAND.K12.NJ.US

TEAM223.COM

INSTAGRAM: @XTREMEHEAT223

TIKTOK: @XTREMEHEAT223

